

PULSE 3

TECHNICAL CARACTRISTICS

BATTERY				BATTERIES CHARGING	
Type of battery	Lithium			On-board charger	yes
Unit weight in kg	38 kg			Main supply	230V-16A
Voltage in Volt	51			Charging time	4,14 kWh / 8,28 kWh
On-board power	4,14 kWh (1 battery) / 8,28 kWh (2 batteries)				< 4h / < 8h
BMS integrated into the battery	yes			Charging power	2 000 W
Heating system	yes				
SPEED AND AUTONOMY				ENGINE AND TRANSMISSION	
	L2e 4,14 kWh	L2e 8,28 kWh	L5e 8,28 kWh	Type of engine	DC brushless motor
Maximum speed when empty	45 km/h	45 km/h	90 km/h	Power rating**	L2e 3,9 kW / L5e 6,8 kW
Autonomy in WMTC cycle*	62 km	121 km	115 km	Transmission	Reducer with différential 1/12
				Tyres + aluminium rims	Front : 90/90 R14 Rear : 140/60 R13

PAYLOAD (kg)

	Litre	L2e 4,14 kWh	L2e 8,28 kWh	L5e 8,28 kWh
Front loading area		20 kg	20 kg	20 kg
Front bag	30 litres	20 kg	20 kg	20 kg
Rigid rear stockage	320 litres	45 kg	45 kg	45 kg
Large-volume rigid rear storage	550 litres	60 kg	60 kg	60 kg
Vehicule weight***		240 kg	278 kg	278 kg
Gross Vehicle Weight Rating		483 kg	521 kg	521 kg

DIMENSIONS (mm)

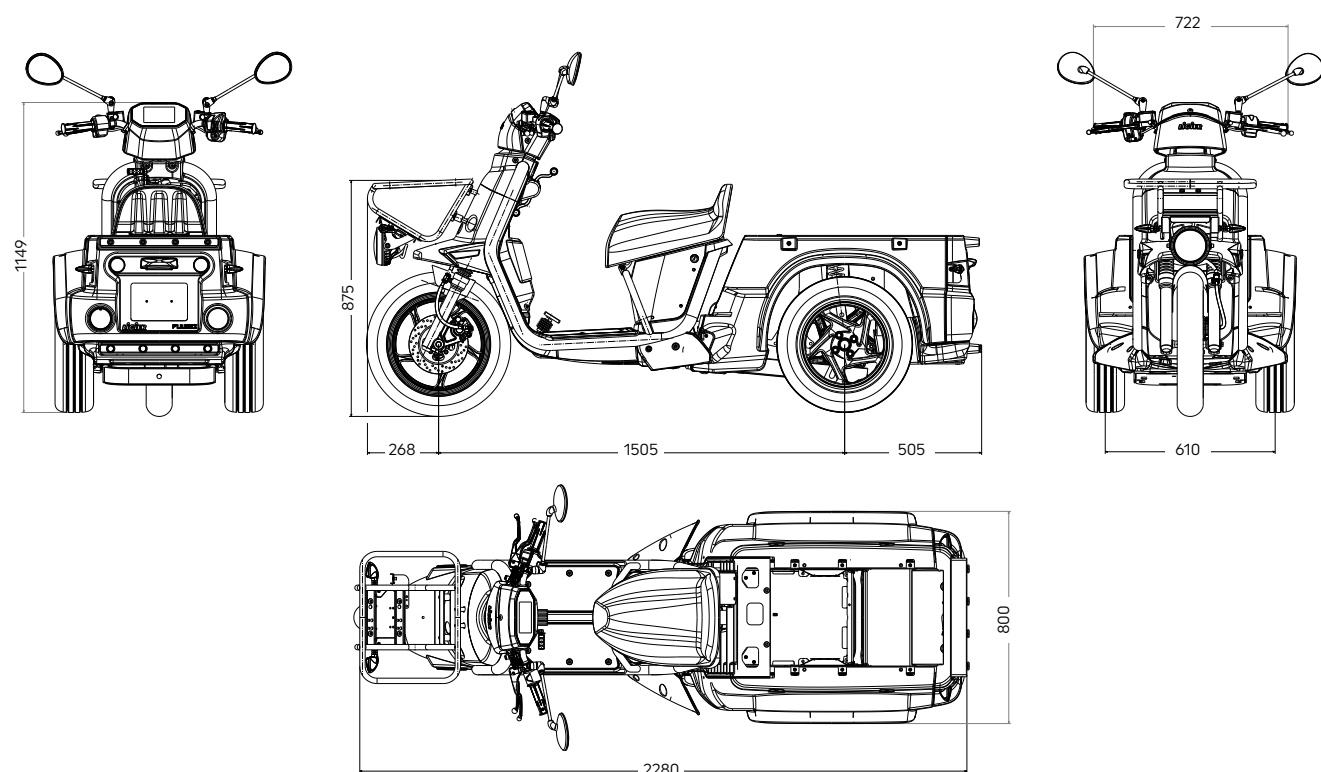

* Theoretical values according to WMTC cycle
** On 30 minutes
*** Unladen weight (excluding luggage rack fluids and containers)



**LIGIER
PROFESSIONAL,
Pioneer in the
micro-utility market
in Europe.**

Ligier Professional's range of electric micro-utility vehicles is an effective response to the challenges of logistics and last-mile delivery, offering transport's mode that better suits to new forms of mobility and local needs.

For more than 10 years, Ligier Professional has been providing European postal services, local authorities and major delivery accounts with a range of practical, agile electric vehicles designed to adapt to traffic constraints in both urban and rural areas.

A service focused on customer needs.

With its extensive distribution and repair network, Ligier Professional guarantees you a close relationship. Take advantage of the expertise of a network of trained professionals to ensure the purchase and maintenance of your vehicle.

Customer satisfaction is at the top of our ambitions, that's why Ligier Group provides quality support to all its partners by offering the intervention of qualified teams, trainings and a personalised and complementary service.

YOUR DEALER :

LIGIER
PROFESSIONAL

AD. BACHMANN AG

Ligier Generalvertretung
Wilerstrasse 16
9554 Tägerschen TG
Telefon 071 918 80 20
info@adbachmannag.ch
www.adbachmannag.ch

See laws in your country. Lithium battery guaranteed for 2 years against defects in electrical, electronic or mechanical components. Lithium battery guaranteed for 5 years or 1500 cycles in the event of an electrical, electronic or mechanical component fault. Battery capacity guaranteed for a total of 12 months, then degressive for the following 48 months according to specific formulas and usage and maintenance recommendations. Chassis manufacturer's warranty for two years, one year for the rear accessory. The manufacturer reserves the right to modify the models described in this document at any time and without prior notice. Photos are non-contractual. The colours shown on these pages are for information purposes only, as the printing process cannot accurately reproduce the brilliance of the colours. Ligier Group S.A.S.U. au capital de 2 691 000 € - Siège social: 105 route d'Hauterive - 03 200 Abrest - R.C.S. de Cusset n° 712 000 272 - Crédits photos: Bastien Aubert - Josselin LEVEQUE - Simpol - Conception: Ligier Group - 09.2023 -

LIGIER PROFESSIONAL'S RANGE



PULSE 3

100% ELECTRIC
SCOOTER

SEPTEMBER 2023

The sectors
of activity we
supply



Mail and parcel
distributors
in Europe



Transporters



Regional
authorities



Major sites
and industries



Tradesmen



100%

**ELECTRIC
EASY TO HANDLE
CUSTOMISABLE**

LIGIER
PROFESSIONAL



PULSE 3

The 3-wheels electric scooter !



INTENSIVE USE

- Reinforced chassis adapted to an **intensive use**
- **Interchangeable body** pannel
- **High rear bumper** for body **protection**

ELECTRIC PERFORMANCE

- **Lithium battery** rechargeable on domestic socket range
- **Autonomy range up to 121km***
- **Recovering energy from braking**

* Valeur théorique selon cycle WMTC et selon homologation.

SAFETY

- **Stabilised parking** without **stand**
- **Audible warning**, pedestrian, reversing beep
- **Third brake light**

PULSE 3

A favourite for last-mile delivery!

PULSE 3

L2e • L5e



Compact and agile!

The Pulse 3 is a three-wheeled electric scooter with a small footprint that gives it easy access to urban areas.



Easy to handle and customisable!

100% customisable, this van can be adapted to the needs of transport and last-mile logistics professionals.



⁽²⁾ In L5e configuration with driver + large-volume rear storage option + front container option (optional)

The + : patented pendulum system!



Original innovation
Ligier Professional

An innovation originally patented by Ligier Professional, this system allows the driving position to be tilted by +/- 30° when cornering, guaranteeing perfect stability both when driving and when stationary.



Made-to-measure customisation!

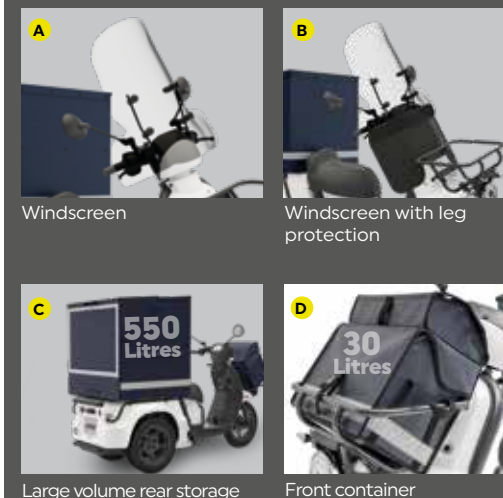

Large volume rear storage

Front container

L2e • L5e
EQUIPMENTS

PULSE 3

STANDARD

OPTIONAL

Vehicle

- Exclusive patented pendulum system: vehicle stability and handling
- Reinforced chassis adapted to intensive and professional use
- Driving position defined by occupational ergonomists
- Dual-density and adjustable 3 lengthwise position comfort + seat
- ABS body tinted mass high UV resistance
- Standard colour: White RAL 1099
- Removable and interchangeable body panels
- Specific colour (additional time)
- All specific adaptations may be studied according to feasibility

Safety

- Braking by independant front/rear hydraulic brakes with sliding callipers and ventilated disk (L2e • L5e)
- Combined braking + pedal (L5e) - Rear disk : Ø180mm / Front disk : Ø220mm
- Parking brake with simultaneous pendulum movement locking (immobilisation of the loaded vehicle (on a 20% slope)
- Stabilised parking without stand
- Right and left rear view mirrors
- Horn, pedestrian warning system, reversing beep, no-driver on seat horn
- High rear bodywork and goods protection bumper
- Left and right driver feet protection side bumpers
- Third brake light

- **A** Windscreen
- **B** Windscreen with leg protection

Loads

- Front luggage carrier
- Reinforced rigid rear stock (320L)
- Under seat container (10L)
- **C** Large volume rear storage (550L)
- **D** Front container (30 L)
- Front and rear stock customisable at customer's request

Electrical performances

- Vehicle charge on domestic plug adaptable according to country
- Fluid and progressive acceleration + reactivity
- Electric regeneration on braking
- Charge cable safety

Comfort

- Reversing function
- Combination counter with optical bonding technology
- Reinforced and expanded central foot rest zone in non-slip aluminium
- Double 5V 1A USB socket under the seat for GPS or smartphone
- On-board 5m charge cable
- Rear sidewall tyre (stability, grip and comfort)

LIGIER
PROFESSIONAL

